

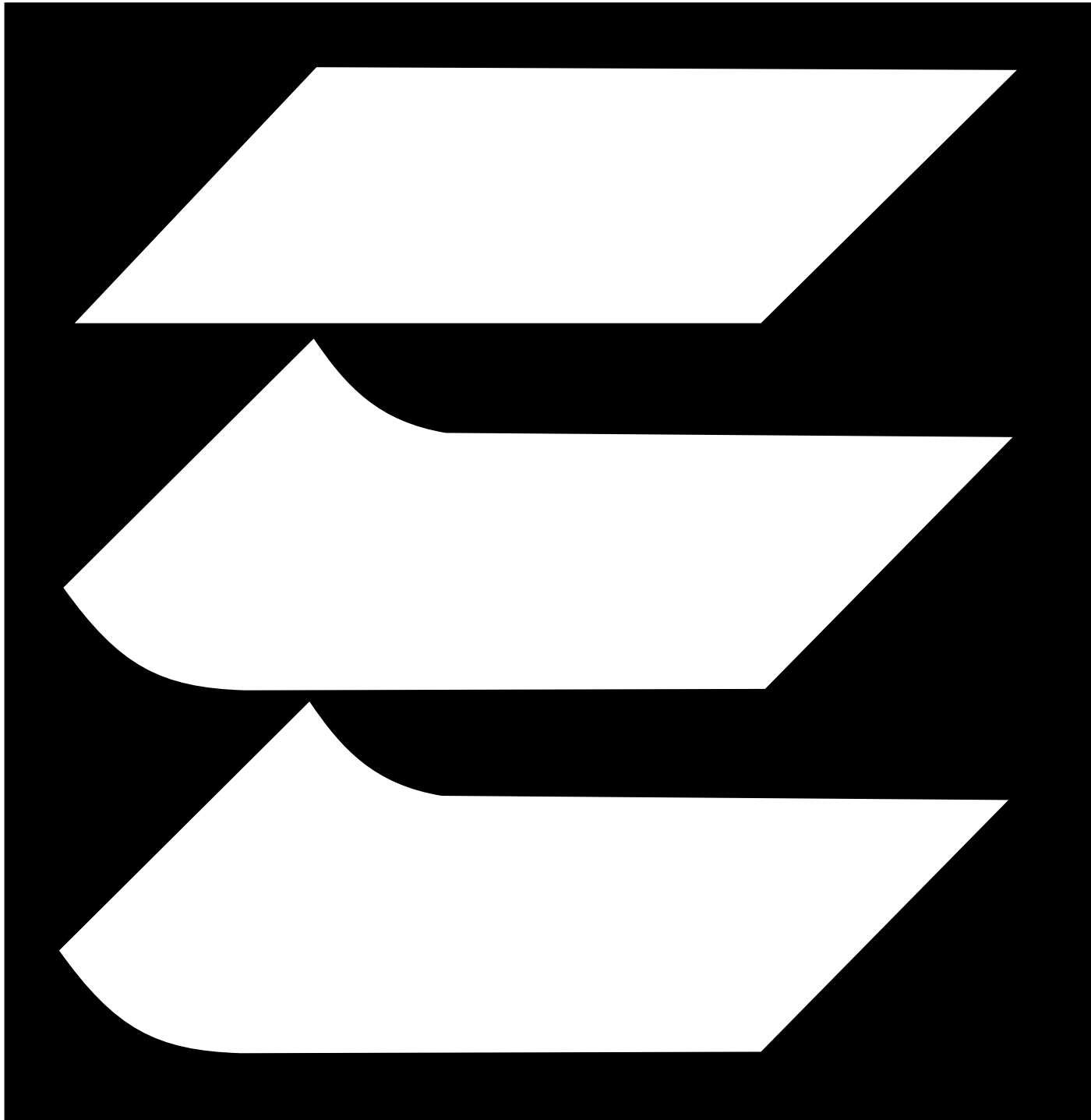

Eastern
CONNECTORS



SPIRAL PIPE & FITTINGS



Slip CONNECTORS

SINGLE WALL SLIP FIT

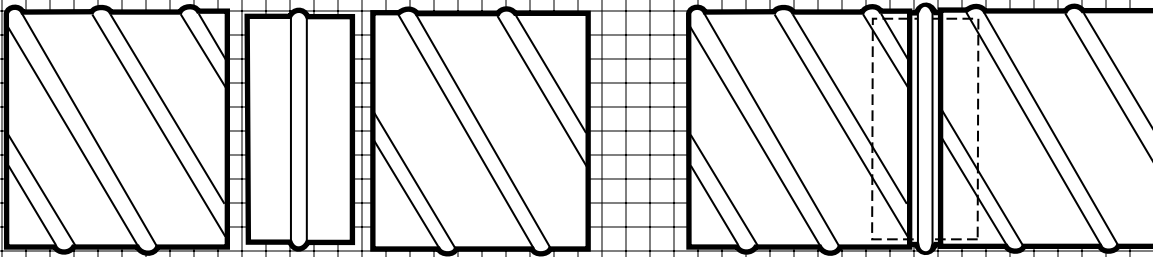

DOUBLE WALL SLIP FIT

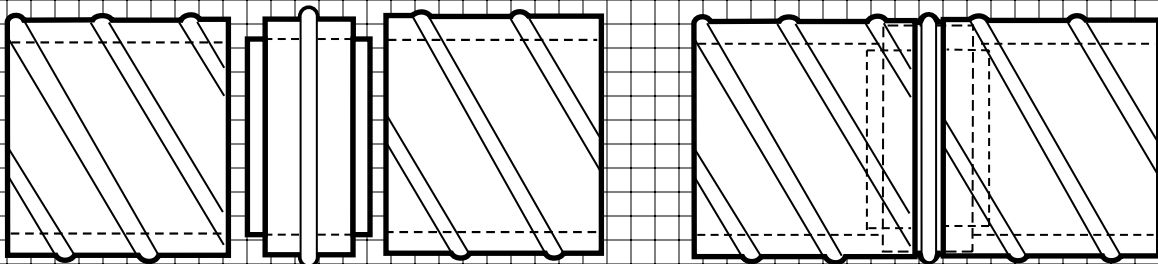

EASTERN TIGHT™ SLIP FIT

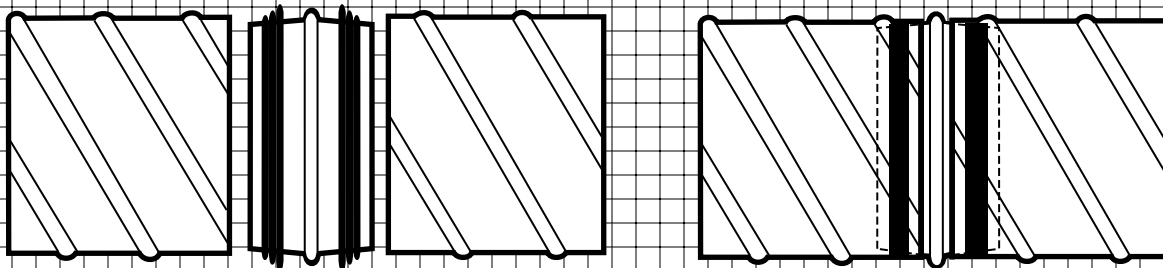

Available up to 36". See our EASTERN TIGHT™ catalog. Also available as double wall.

Protected by the following U.S. Patents: D437,034; D435,090; D430,482; D427,673; D427,668; D427,667; D553,238; D551,336.



Eastern Flange CONNECTORS

Eastern Flange* is an 18-gauge galvanized steel flange for assembling spiral pipe and fittings. It is attached to the end of the duct by spot welding and sealing.

Eastern Flange is joined in the field using #10 TEK screws, on 8" centers, and a sealing gasket. The butyl, or neoprene gasket, is placed between mating flanges with the flanges screwed together.

When the Eastern Flange is provided for dual wall spiral pipe and fittings, a second factory installed flange is installed to keep the inner liner concentric and to eliminate the need to make a connection at the inner wall.

Eastern Flange connectors are covered by one or more of the following U.S. Patents: 7,287,407; D518,885; D517,679; D516,698; D516,697.

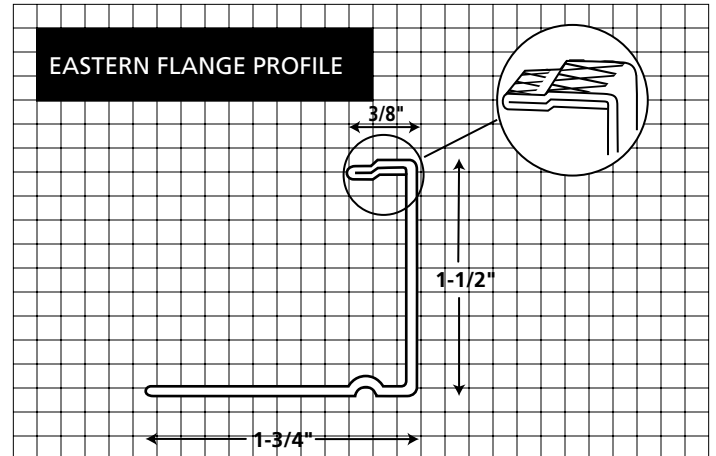

SINGLE WALL FLANGE

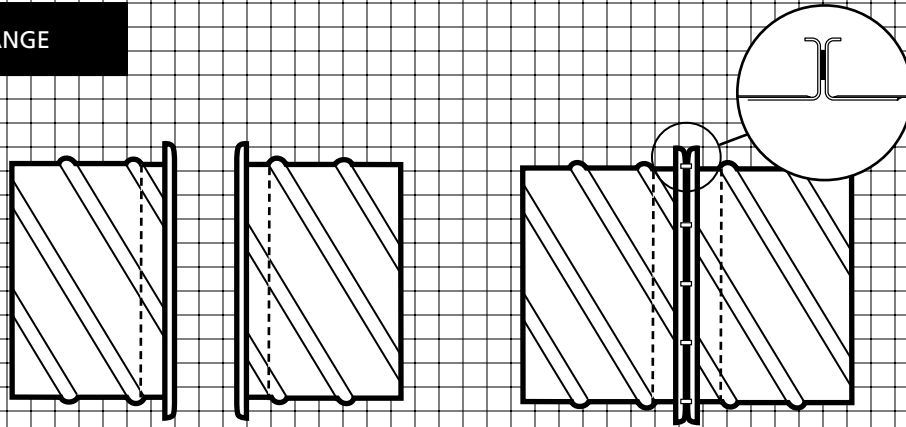

DOUBLE WALL FLANGE

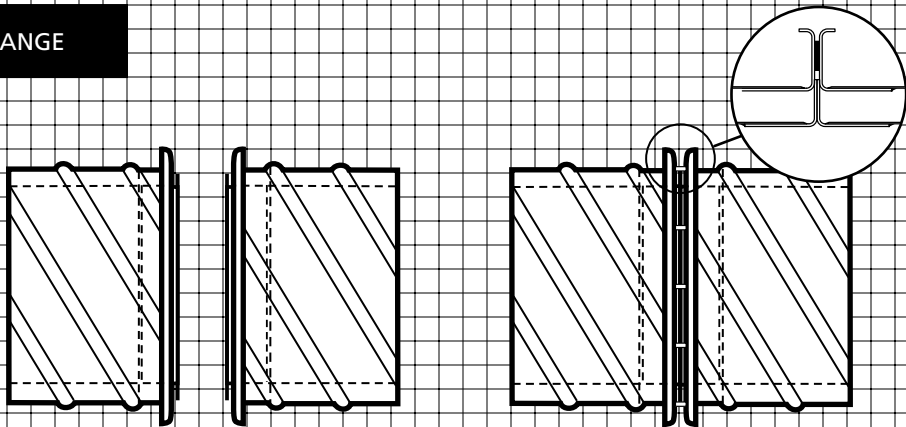



Vanstone Flange CONNECTORS

ROUND ANGLE IRON RING DIMENSION

| ORDER SIZE | ANGLE MILD STEEL | I.D. | BOLT HOLES | HOLE SIZE | BOLT CIRCLE | WEIGHT LBS. |
|------------|------------------|---------|------------|--------------|-------------|-------------|
| 3 | Pressed | 3 1/16 | 6 | 4 | 5/16" 0.70 | |
| 4 | 10 ga | 4 1/16 | 6 | 5/16" | 5 1/16" | 0.85 |
| 5 | | 5 1/16 | 6 | 5/16" | 6 1/16" | 1.20 |
| 6 | 1 1/4 x | 6 1/8 | 6 | 3/8" | 7 1/16" | 1.75 |
| 7 | 1 1/4 x | 7 1/8 | 6 | 3/8" | 8 1/2" | 2.00 |
| 8 | 1/2 | 8 1/8 | 6 | 3/8" | 9 1/16" | 2.25 |
| 9 | | 9 1/8 | 6 | 3/8" | 10 1/16" | 2.50 |
| 10 | | 10 1/8 | 6 | 3/8" | 11 1/16" | 2.75 |
| 11 | | 11 1/8 | 6 | 3/8" | 12 1/4" | 3.00 |
| 12 | 1 1/2 x | 12 3/16 | 8 | 7/16" x 3/8" | 14" | 4.00 |
| 13 | 1 1/2 x | 13 3/16 | 8 | 7/16" x 3/8" | 15" | 4.25 |
| 14 | 1/2 | 14 3/16 | 8 | 7/16" x 3/8" | 16" | 4.75 |
| 15 | | 15 3/16 | 8 | 7/16" x 3/8" | 17" | 5.00 |
| 16 | 1 1/2 x | 16 3/16 | 8 | 7/16" x 3/8" | 18" | 8.00 |
| 17 | 1 1/2 x | 17 3/16 | 8 | 7/16" x 3/8" | 19" | 8.25 |
| 18 | 1/2 | 18 3/16 | 8 | 7/16" x 3/8" | 20" | 8.50 |
| 19 | | 19 3/16 | 12 | 7/16" x 3/8" | 20 3/4" | 8.75 |
| 20 | | 20 3/16 | 12 | 7/16" x 3/8" | 21 3/4" | 9.50 |
| 21 | | 21 3/16 | 12 | 7/16" x 3/8" | 22 3/4" | 10.25 |
| 22 | | 22 3/16 | 12 | 7/16" x 3/8" | 23 3/4" | 10.75 |
| 23 | | 23 3/16 | 12 | 7/16" x 3/8" | 24 7/8" | 11.25 |
| 24 | | 24 3/16 | 12 | 7/16" x 3/8" | 25 1/8" | 11.75 |
| 25 | 2 x 2 x | 25 3/16 | 16 | 7/16" x 3/8" | 26 7/8" | 15.75 |
| 26 | 3/16 | 26 3/16 | 16 | 7/16" x 3/8" | 28 3/8" | 16.50 |
| 27 | | 27 3/16 | 16 | 7/16" x 3/8" | 29 3/8" | 16.75 |
| 28 | | 28 3/16 | 16 | 7/16" x 3/8" | 30 3/8" | 18.00 |
| 29 | | 29 3/16 | 16 | 7/16" x 3/8" | 31 3/8" | 18.75 |
| 30 | | 30 3/16 | 16 | 7/16" x 3/8" | 32 3/8" | 19.50 |
| 31 | | 31 3/16 | 16 | 7/16" x 3/8" | 33 3/8" | 19.75 |
| 32 | | 32 3/16 | 16 | 7/16" x 3/8" | 34 3/8" | 20.00 |
| 33 | | 33 3/16 | 16 | 7/16" x 3/8" | 35 3/8" | 21.25 |
| 34 | | 34 3/16 | 16 | 7/16" x 3/8" | 36 3/8" | 22.50 |
| 35 | | 35 3/16 | 16 | 7/16" x 3/8" | 37 3/8" | 22.75 |
| 36 | | 36 3/16 | 16 | 7/16" x 3/8" | 38 3/8" | 23.00 |
| 37 | | 37 3/16 | 24 | 7/16" x 3/8" | 39 3/8" | 23.75 |
| 38 | | 38 3/16 | 24 | 7/16" x 3/8" | 40 3/8" | 24.50 |
| 39 | | 39 3/16 | 24 | 7/16" x 3/8" | 41 3/8" | 25.00 |
| 40 | | 40 3/16 | 24 | 7/16" x 3/8" | 42 3/8" | 25.75 |
| 41 | | 41 3/16 | 24 | 7/16" x 3/8" | 43 3/8" | 26.25 |
| 42 | | 42 3/16 | 24 | 7/16" x 3/8" | 44 3/8" | 26.50 |
| 43 | | 43 3/16 | 24 | 7/16" x 3/8" | 45 3/8" | 27.50 |
| 44 | | 44 3/16 | 24 | 7/16" x 3/8" | 46 3/8" | 28.00 |
| 45 | | 45 3/16 | 24 | 7/16" x 3/8" | 47 3/8" | 28.50 |
| 46 | | 46 3/16 | 24 | 7/16" x 3/8" | 48 3/8" | 29.00 |
| 47 | | 47 3/16 | 24 | 7/16" x 3/8" | 49 3/8" | 30.00 |
| 48 | | 48 3/16 | 24 | 7/16" x 3/8" | 50 3/8" | 30.75 |
| 49 | | 49 3/16 | 24 | 7/16" x 3/8" | 51 3/8" | 31.50 |
| 50 | | 50 3/16 | 24 | 7/16" x 3/8" | 52 3/8" | 32.00 |
| 52 | | 52 3/16 | 24 | 7/16" x 3/8" | 54 3/8" | 33.75 |
| 54 | | 54 3/16 | 24 | 7/16" x 3/8" | 56 3/8" | 35.00 |
| 56 | | 56 3/16 | 24 | 7/16" x 3/8" | 58 3/8" | 36.25 |
| 58 | | 58 3/16 | 24 | 7/16" x 3/8" | 60 3/8" | 37.50 |
| 60 | | 60 3/16 | 24 | 7/16" x 3/8" | 62 3/8" | 38.75 |
| 62 | | 62 3/16 | 24 | 7/16" x 3/8" | 64 3/8" | 40.00 |
| 64 | | 64 3/16 | 24 | 7/16" x 3/8" | 66 3/8" | 41.50 |
| 66 | | 66 3/16 | 24 | 7/16" x 3/8" | 68 3/8" | 42.75 |
| 68 | | 68 3/16 | 24 | 7/16" x 3/8" | 70 3/8" | 44.00 |
| 70 | | 70 3/16 | 24 | 7/16" x 3/8" | 72 3/8" | 45.25 |
| 72 | | 72 3/16 | 24 | 7/16" x 3/8" | 74 3/8" | 46.50 |

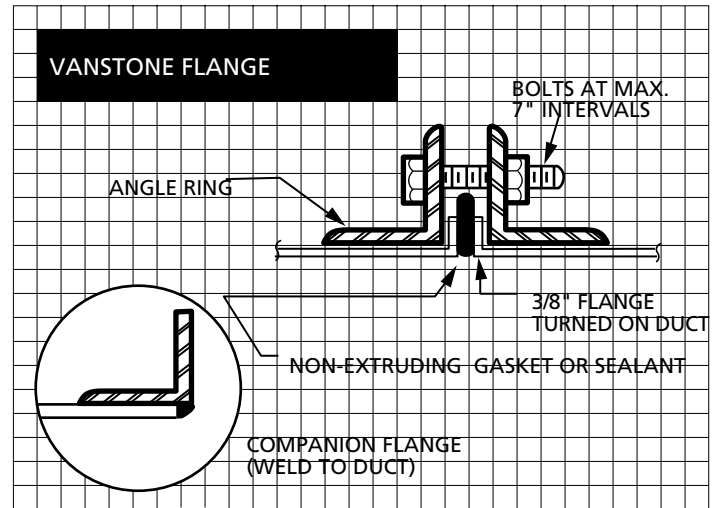

OVAL ANGLE RING DIMENSIONS

8" typ. on the flat span

| a Minor Axis | Bolt Hole Diameter | Number of Bolts on Curved Sides | LxF Nominal Size | t Nominal Thickness |
|-----------------|--------------------|---------------------------------|---------------------|------------------------|
| 3"-5" | 5/32" | 6 | 1" x 1" | 10 gauge |
| 5"-11" | 3/8" | 6 | 1 1/4" x 1 1/4" | 1/8" |
| 12"-14" | 7/16" x 3/8" | 8 | 1 1/2" x 1 1/2" | 1/8" |
| 16"-18" | 7/16" x 3/8" | 8 | 1 1/2" x 1 1/2" | 3/16" |
| 19"-24" | 7/16" x 3/8" | 12 | 1 1/2" x 1 1/2" | 3/16" |
| 25"-36" | 7/16" x 3/8" | 16 | 2" x 2" | 3/16" |
| 37"-50" | 7/16" x 3/8" | 24 | 2" x 2" | 3/16" |

Standard Rings are hot-rolled steel.
Galvanized, aluminum, and stainless steel are available.

*EASTERN TIGHT is a trademark of Eastern Sheet Metal, LLC and may not be used without prior written authorization.