

Round Self-Sealing HVAC SPIRAL PIPE & FITTINGS



EASTERN TIGHT™

EASTERN TIGHT Fittings will save you money by reducing installation time by eliminating joint sealing. They feature a triple-lipped EPDM rubber gasket, held in place with a 180° hemmed edge, that provides a reliable, airtight seal. EASTERN TIGHT Fittings are suitable for use for temperatures ranging from -20° F to 212° F. When tested in accordance with ASTM E84, EASTERN TIGHT Fittings have flame-spread and smoke-developed ratings of 0/0.

Full-bodied fittings, couplings, reducers, elbows, and taps are available in even and odd sizes from 3" through 10" in diameter, and even sizes up to 36" in diameter. Fittings are secured to the duct with self-tapping screws uniformly located around the circumference per SMACNA standards.

EASTERN TIGHT Fittings are available in single-wall construction, fabricated from galvanized, galvanized and stainless steel. EASTERN TIGHT Fittings have been independently tested and meet SMACNA Class 3 leakage standards for -2" WG to +10" WG.

EASTERN TIGHT ROUND SPIRAL DUCT AND FITTINGS CONSTRUCTION STANDARDS

Gauge selection for galvanized steel (ASTM A653).

Fittings are assembled with stitch welds, spot welds, or standing seams and are sealed. All galvanized spiral pipe 6" and larger is corrugated. All spiral pipe from other materials will be smooth.

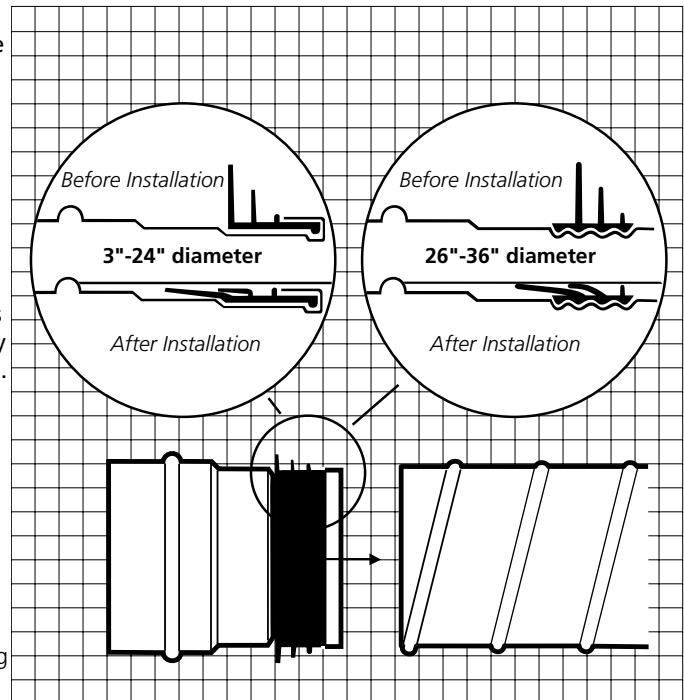

DUCT DIAMETER	2005 SMACNA 10" WG POSITIVE SPIRAL PIPE		2005 SMACNA 2" WG NEGATIVE SPIRAL PIPE		EASTERN TIGHT Fittings and Couplings are covered by the following U.S. Patents: D437,034; D435,090; D430,482; D427,673; D427,668; D427,667; D553,238; D551,336
	PIPE	FITTINGS	PIPE	FITTINGS	
3"-6"	26	26	26	26	
7"-18"	26	26	26	26	
9"-10"	26	26	26	26	
11"-12"	26	26	26	26	
13"-14"	26	26	26	24	
15"-16"	26	26	26	24	
17"-18"	26	26	26R	24R	
19"-20"	26	24	26R	24R	
21"-22"	26	24	26R	24R	
23"-24"	26	24	26R	24R	
25"-30"	24	22	26R	24R	
31"-36"	24	22	26R	24R	

R = Reinforcement ring at 12' maximum spacing. Individual fittings may not have reinforcement.

Inner Shell for EASTERN TIGHT Dual Wall

Gauge selection for inner shell. Standard material for the inner shell of spiral pipe is Spirorib perforated steel (ASTM A653), with 3/32" holes on 3/16" staggered centers for a free area of 23%. Standard material for the inner shell of fittings is solid steel. Fittings are also available with a perforated liner and spiral pipe with a solid liner.

DUCT DIAMETER	SPIRORIB PIPE		SPIRAL PIPE
	PIPE	FITTINGS	
3"-26"	26	22	26
27"-36"	26	22	26

Standard insulation is 1" thick, 1 pound per cubic foot density, with a thermal conductivity (ASTM C 518) @ 75° F mean temperature of 0.26 (BTU-in./hr.ft.2°F)

Surface burning characteristics (ASTM E 84, UL 723)
25 flame spread
50 smoke developed.

Sound absorption coefficients. (ASTM C 423, Type A)

Frequency, Hz						
125	250	500	1000	2000	4000	NRC
0.17	0.24	0.62	0.79	0.88	0.96	0.65

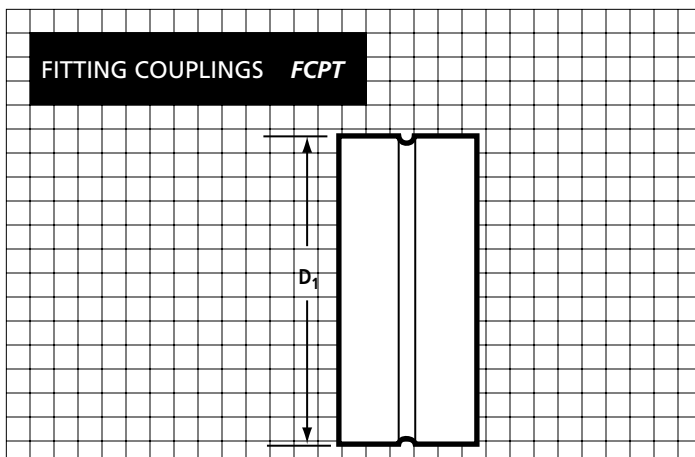
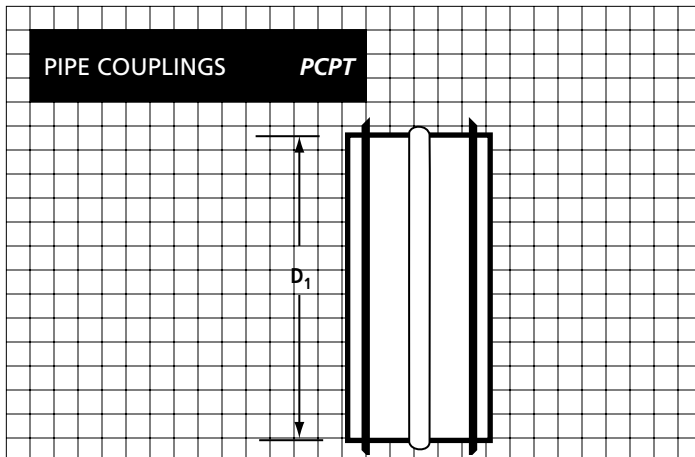
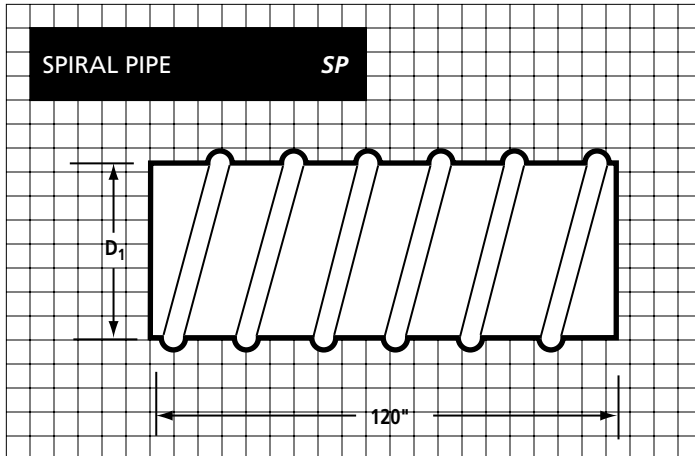

SPIRAL PIPE		
	D_1	WT.
SP3	3"	8.1#
SP4	4"	10.8#
SP5	5"	13.5#
SP6	6"	16.2#
SP7	7"	18.9#
SP8	8"	21.6#
SP9	9"	24.3#
SP10	10"	27.0#
SP12	12"	32.4#
SP14	14"	37.8#
SP16	16"	43.2#
SP18	18"	48.6#
SP20	20"	54.0#
SP22	22"	59.4#
SP24	24"	64.8#
SP26	26"	90.4#
SP28	28"	97.4#
SP30	30"	104.3#
SP32	32"	111.3#
SP34	34"	118.2#
SP36	36"	125.2#

COUPLINGS		
	D_1	WT.
PCPT3/FCPT3	3"	0.3#
PCPT4/FCPT4	4"	0.4#
PCPT5/FCPT5	5"	0.5#
PCPT6/FCPT6	6"	0.5#
PCPT7/FCPT7	7"	0.6#
PCPT8/FCPT8	8"	0.7#
PCPT9/FCPT9	9"	0.8#
PCPT10/FCPT10	10"	0.9#
PCPT12/FCPT12	12"	1.1#
PCPT14/FCPT14	14"	1.3#
PCPT16/FCPT16	16"	1.4#
PCPT18/FCPT18	18"	1.6#
PCPT20/FCPT20	20"	2.3#
PCPT22/FCPT22	22"	2.5#
PCPT24/FCPT24	24"	2.7#
PCPT26/FCPT26	26"	3.6#
PCPT28/FCPT28	28"	3.9#
PCPT30/FCPT30	30"	4.2#
PCPT32/FCPT32	32"	4.4#
PCPT34/FCPT34	34"	4.7#
PCPT36/FCPT36	36"	5.0#

90° PRESSED ELBOW PE90T

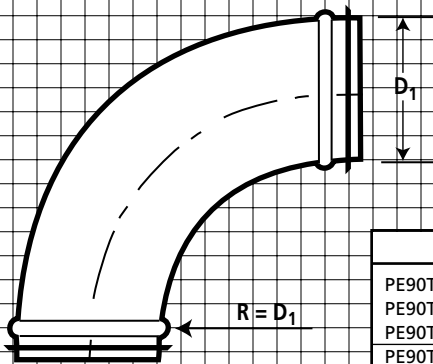

	D_1	WT.
PE90T3	3"	1.1#
PE90T4	4"	1.7#
PE90T5	5"	2.5#
PE90T6	6"	3.4#
PE90T7	7"	4.4#
PE90T8	8"	5.5#
PE90T9	9"	6.8#
PE90T10	10"	8.2#
PE90T12	12"	11.1#

45° PRESSED ELBOW PE45T

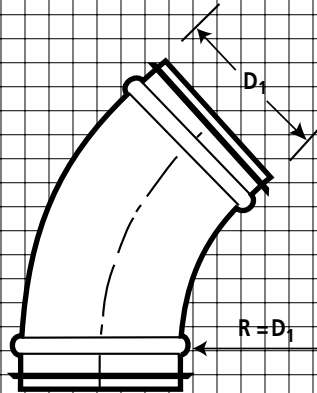

	D_1	WT.
PE45T3	3"	0.6#
PE45T4	4"	1.0#
PE45T5	5"	1.4#
PE45T6	6"	1.8#
PE45T7	7"	2.4#
PE45T8	8"	3.0#
PE45T9	9"	3.7#
PE45T10	10"	4.4#
PE45T12	12"	6.0#

90° 5-PC. ELBOW E90T

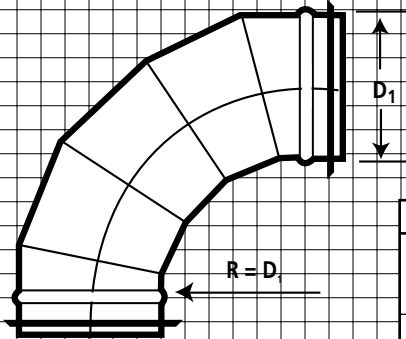

	D_1	WT.
E90T14	14"	12.0#
E90T16	16"	15.3#
E90T18	18"	19.1#
E90T20	20"	29.7#
E90T22	22"	42.9#
E90T24	24"	41.9#
E90T26	26"	59.3#
E90T28	28"	68.4#
E90T30	30"	78.0#
E90T32	32"	88.3#
E90T34	34"	99.2#
E90T36	36"	100.8#

45° 3-PC. ELBOW E45T

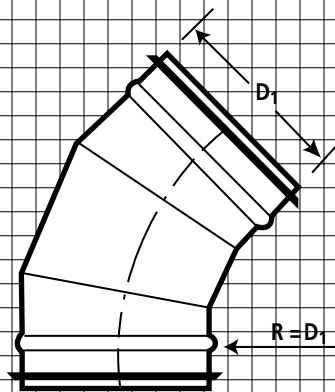

	D_1	WT.
E45T14	14"	6.6#
E45T16	16"	8.4#
E45T18	18"	10.3#
E45T20	20"	16.0#
E45T22	22"	19.0#
E45T24	24"	22.3#
E45T26	26"	31.4#
E45T28	28"	36.1#
E45T30	30"	41.0#
E45T32	32"	46.3#
E45T34	34"	51.9#
E45T36	36"	57.8#



EASTERN TIGHT™ PRESSED TEES

FIELD INSTALLED PRESSED TAP
PFTT

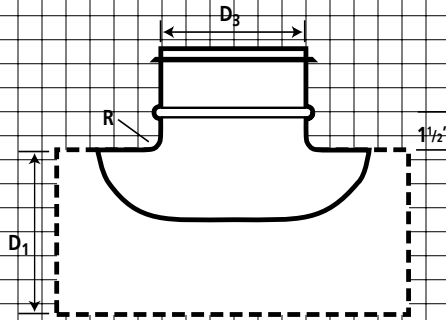

	D ₃ /D ₁	R	L	WT.
PFTCT44	4"/4"	.394"	14"	.4#
PFTCT46	4"/6"	.394"	14"	.4#
PFTCT48	4"/8"	.394"	14"	.4#
PFTCT410	4"/10"	.394"	14"	.4#
PFTCT4120	4"/12"	.394"	14"	.4#
PFTCT66	6"/6"	.787"	16"	.8#
PFTCT68	6"/8"	.787"	16"	.8#
PFTCT610	6"/10"	.787"	16"	.8
PFTCT612	6"/12"	.787"	16"	.8#
PFTCT614	6"/14"	.787"	16"	.8#
PFTCT616	6"/16"	.787"	16"	.8#
PFTCT618	6"/18"	.787"	16"	.8#
PFTCT88	8"/8"	.787"	18"	1.2#
PFTCT810	8"/10"	.787"	18"	1.2#
PFTCT812	8"/12"	.787"	18"	1.2#
PFTCT814	8"/14"	.787"	18"	1.2#
PFTCT816	8"/16"	.787"	18"	1.2#
PFTCT818	8"/18"	.787"	18"	1.2#
PFTCT820	8"/20"	.787"	18"	1.2#
PFTCT822	8"/22"	.787"	18"	1.2#
PFTCT824	8"/24"	1.0"	20"	2.1#
PFTCT1010	10"/10"	1.0"	20"	2.1#
PFTCT1012	10"/12"	1.0"	20"	2.1#
PFTCT1014	10"/14"	1.0"	20"	2.1#
PFTCT1016	10"/16"	1.0"	20"	2.1#
PFTCT1018	10"/18"	1.0"	20"	2.1#
PFTCT1020	10"/20"	1.0"	20"	2.1#
PFTCT1022	10"/22"	1.0"	20"	2.1#
PFTCT1024	10"/24"	1.0"	20"	2.1#
PFTCT1212	12"/12"	1.0"	22"	2.7#
PFTCT1214	12"/14"	1.0"	22"	2.7#
PFTCT1216	12"/16"	1.0"	22"	2.7#
PFTCT1218	12"/18"	1.0"	22"	2.7#
PFTCT1220	12"/20"	1.0"	22"	2.7#
PFTCT1222	12"/22"	1.0"	22"	2.7#
PFTCT1224	12"/24"	1.0"	22"	2.7#

PRESSED TEE
PTT

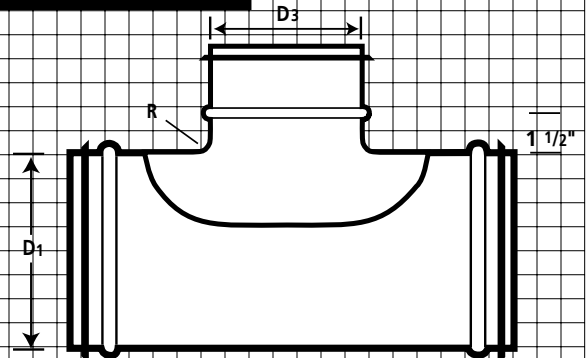

	D ₃ /D ₁	R	L	WT.
PTT44	4"/4"	.394"	14"	1.6#
PTT46	4"/6"	.394"	14"	2.1#
PTT48	4"/8"	.394"	14"	2.7#
PTT410	4"/10"	.394"	14"	3.2#
PTT412	4"/12"	.394"	14"	3.8#
PTT66	6"/6"	.787"	16"	2.7#
PTT68	6"/8"	.787"	16"	3.4#
PTT610	6"/10"	.787"	16"	4.0#
PTT612	6"/12"	.787"	16"	4.6#
PTT614	6"/14"	.787"	16"	5.3#
PTT616	6"/16"	.787"	16"	5.9#
PTT618	6"/18"	.787"	16"	6.5#
PTT88	8"/8"	.787"	18"	4.1#
PTT810	8"/10"	.787"	18"	4.8#
PTT812	8"/12"	.787"	18"	5.5#
PTT814	8"/14"	.787"	18"	6.2#
PTT816	8"/16"	.787"	18"	6.9#
PTT818	8"/18"	.787"	18"	7.7#
PTT820	8"/20"	.787"	18"	10.3#
PTT822	8"/22"	.787"	18"	11.3#
PTT824	8"/24"	1.0"	20"	12.2#
PTT1010	10"/10"	1.0"	20"	6.1#
PTT1012	10"/12"	1.0"	20"	6.9#
PTT1014	10"/14"	1.0"	20"	7.7#
PTT1016	10"/16"	1.0"	20"	8.5#
PTT1018	10"/18"	1.0"	20"	9.3#
PTT1020	10"/20"	1.0"	20"	12.3#
PTT1022	10"/22"	1.0"	20"	13.3#
PTT1024	10"/24"	1.0"	20"	14.3#
PTT1212	12"/12"	1.0"	22"	8.0#
PTT1214	12"/14"	1.0"	22"	8.9#
PTT1216	12"/16"	1.0"	22"	9.7#
PTT1218	12"/18"	1.0"	22"	10.6#
PTT1220	12"/20"	1.0"	22"	13.9#
PTT1222	12"/22"	1.0"	22"	15.0#
PTT1224	12"/24"	1.0"	22"	16.1#



EASTERN TIGHT™ CONICAL TEES

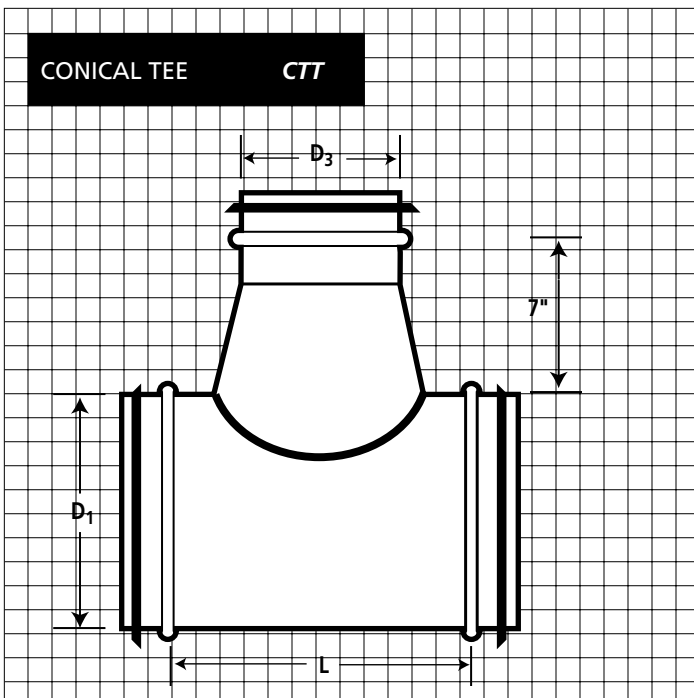
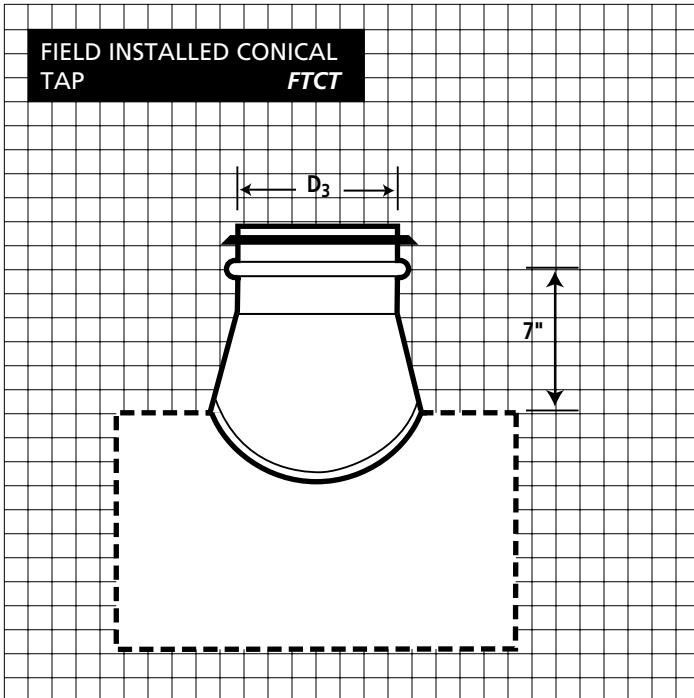

	D_1/D_2	L	WT.(FTCT)	WT.(CTT)
FTCT1414/CTT1414	14"/14"	20"	3.8#	11.5#
FTCT1416/CTT1416	14"/16"	20"	3.8#	12.7#
FTCT1418/CTT1418	14"/18"	20"	3.8#	13.9#
FTCT1420/CTT1420	14"/20"	20"	3.8#	19.3#
FTCT1422/CTT1422	14"/22"	20"	3.8#	20.8#
FTCT1424/CTT1424	14"/24"	20"	3.8#	22.4#
FTCT1616/CTT1616	16"/16"	22"	4.3#	13.8#
FTCT1618/CTT1618	16"/18"	22"	4.3#	15.1#
FTCT1620/CTT1620	16"/20"	22"	4.3#	20.9#
FTCT1622/CTT1622	16"/22"	22"	4.3#	22.5#
FTCT1624/CTT1624	16"/24"	22"	4.3#	24.2#
FTCT1818/CTT1818	18"/18"	24"	4.9#	16.2#
FTCT1820/CTT1820	18"/20"	24"	4.9#	22.5#
FTCT1822/CTT1822	18"/22"	24"	4.9#	24.3#
FTCT1824/CTT1824	18"/24"	24"	4.9#	26.0#
FTCT2020/CTT2020	20"/20"	26"	6.9#	27.1#
FTCT2022/CTT2022	20"/22"	26"	6.9#	26.0#
FTCT2024/CTT2024	20"/24"	26"	6.9#	27.8#
FTCT2026/CTT2026	20"/26"	26"	6.9#	36.2#
FTCT2222/CTT2222	22"/22"	28"	7.5#	27.7#
FTCT2224/CTT2224	22"/24"	28"	7.5#	29.7#
FTCT2226/CTT2226	22"/26"	28"	7.5#	38.5#
FTCT2228/CTT2228	22"/28"	28"	7.5#	40.9#
FTCT2424/CTT2424	24"/24"	30"	9.2#	31.5#
FTCT2426/CTT2426	24"/26"	30"	9.2#	40.9#
FTCT2428/CTT2428	24"/28"	30"	9.2#	43.4#
FTCT2430/CTT2430	24"/30"	30"	9.2#	46.0#
FTCT2626/CTT2626	26"/26"	32"	10.8#	42.9#
FTCT2628/CTT2628	26"/28"	32"	10.8#	45.9#
FTCT2630/CTT2630	26"/30"	32"	10.8#	48.6#
FTCT2632/CTT2632	26"/32"	32"	10.8#	51.3#
FTCT2828/CTT2828	28"/28"	34"	11.6#	48.2#
FTCT2830/CTT2830	28"/30"	34"	11.6#	51.2#
FTCT2832/CTT2832	28"/32"	34"	11.6#	54.0#
FTCT2834/CTT2834	28"/34"	34"	11.6#	56.9#
FTCT3030/CTT3030	30"/30"	36"	12.4#	53.8#
FTCT3032/CTT3032	30"/32"	36"	12.4#	56.8#
FTCT3034/CTT3034	30"/34"	36"	12.4#	59.8#
FTCT3036/CTT3036	30"/36"	36"	12.4#	62.8#
FTCT3232/CTT3232	32"/32"	38"	13.2#	59.7#
FTCT3234/CTT3234	32"/34"	38"	13.2#	62.7#
FTCT3236/CTT3236	32"/36"	38"	13.2#	65.8#
FTCT3434/CTT3434	34"/34"	40"	14.0#	65.8#
FTCT3436/CTT3436	34"/36"	40"	14.0#	68.8#
FTCT3636/CTT3636	36"/36"	42"	14.8#	71.8#

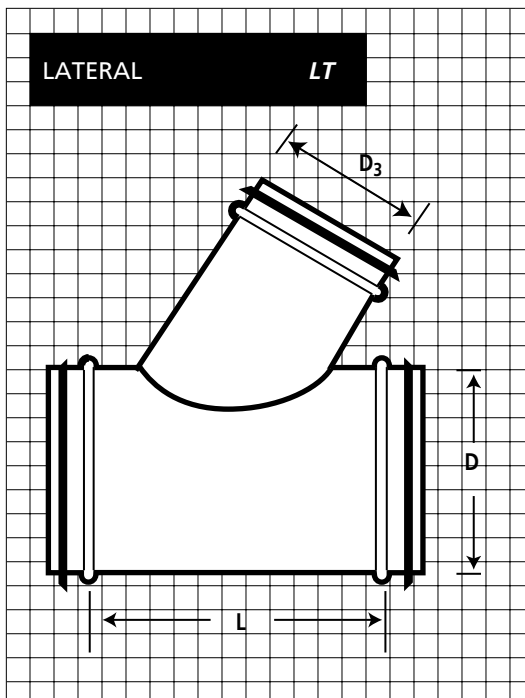
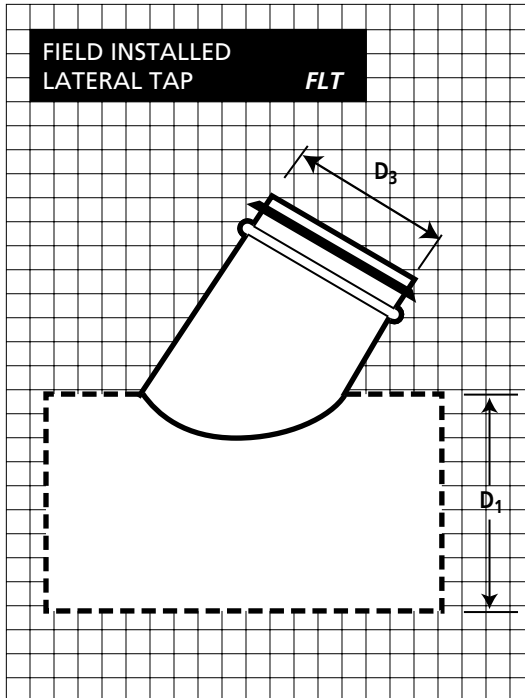

	D_3/D_1	WT.(FLT)	WT.(LT)	L(LT)		D_3/D_1	WT.(FLT)	WT.(LT)	L(LT)
FLT44/LT44	4"/4"	1.0#	2.3#	9"	FLT1422/LT1422	14"/22"	4.8#	24.3#	23 1/8"
FLT46/LT46	4"/6"	1.0#	3.0#	9"	FLT1424/LT1424	14"/24"	4.8#	26.0#	23 1/8"
FLT48/LT48	4"/8"	1.0#	3.8#	9"	FLT1616/LT1616	16"/16"	5.8#	16.8#	26 5/8"
FLT410/LT410	4"/10"	1.0#	4.6#	9"	FLT1618/LT1618	16"/18"	5.8#	18.3#	26 5/8"
FLT412/LT412	4"/12"	1.0#	5.3#	9"	FLT1620/LT1620	16"/20"	5.8#	25.2#	26 5/8"
FLT414/LT414	4"/14"	1.0#	6.1#	9"	FLT1622/LT1622	16"/22"	5.8#	27.1#	26 5/8"
FLT416/LT416	4"/16"	1.0#	6.9#	9"	FLT1624/LT1624	16"/24"	5.8#	29.0#	26 5/8"
FLT66/LT66	6"/6"	1.5#	3.9#	12 1/2"	FLT1818/LT1818	18"/18"	6.9#	20.3#	29 7/8"
FLT68/LT68	6"/8"	1.5#	4.8#	12 1/2"	FLT1820/LT1820	18"/20"	6.9#	28.0#	29 7/8"
FLT610/LT610	6"/10"	1.5#	5.6#	12 1/2"	FLT1822/LT1822	18"/22"	6.9#	30.1#	29 7/8"
FLT612/LT612	6"/12"	1.5#	6.5#	12 1/2"	FLT1824/LT1824	18"/24"	6.9#	32.2#	29 7/8"
FLT614/LT614	6"/14"	1.5#	7.4#	12 1/2"	FLT2020/LT2020	20"/20"	10.3#	30.9#	32 1/4"
FLT616/LT616	6"/16"	1.5#	8.3#	12 1/2"	FLT2022/LT2022	20"/22"	10.3#	33.2#	32 1/4"
FLT618/LT618	6"/18"	1.5#	9.2#	12 1/2"	FLT2024/LT2024	20"/24"	10.3#	35.4#	32 1/4"
FLT88/LT88	8"/8"	2.2#	5.8#	15 5/8"	FLT2026/LT2026	20"/26"	10.3#	45.7#	32 1/4"
FLT810/LT810	8"/10"	2.2#	6.8#	15 5/8"	FLT2222/LT2222	22"/22"	12.0#	36.3#	35 1/8"
FLT812/LT812	8"/12"	2.2#	7.8#	15 5/8"	FLT2225/LT2224	22"/24"	12.0#	38.7#	35 1/8"
FLT814/LT814	8"/14"	2.2#	8.8#	15 5/8"	FLT2226/LT2226	22"/26"	12.0#	50.0#	35 1/8"
FLT816/LT816	8"/16"	2.2#	9.8#	15 5/8"	FLT2228/LT2228	22"/28"	12.0#	52.9#	35 1/8"
FLT818/LT818	8"/18"	2.2#	10.8#	15 5/8"	FLT2424/LT2424	24"/24"	13.7#	42.2#	37 1/8"
FLT820/LT820	8"/20"	2.2#	15.1#	15 5/8"	FLT2426/LT2426	24"/26"	13.7#	54.4#	37 1/8"
FLT822/LT822	8"/22"	2.2#	16.4#	15 5/8"	FLT2428/LT2428	24"/28"	13.7#	57.4#	37 1/8"
FLT1024/LT824	8"/24"	2.2#	17.7#	15 5/8"	FLT2430/LT2430	24"/30"	13.7#	60.5#	37 1/8"
FLT1010/LT1010	10"/10"	3.0#	8.0#	18 1/8"	FLT2626/LT2626	26"/26"	18.9#	58.9#	40 3/4"
FLT1012/LT1012	10"/12"	3.0#	9.2#	18 1/8"	FLT2628/LT2628	26"/28"	18.9#	62.1#	40 3/4"
FLT1014/LT1014	10"/14"	3.0#	10.3#	18 1/8"	FLT2630/LT2630	26"/30"	18.9#	65.4#	40 3/4"
FLT1016/LT1016	10"/16"	3.0#	11.4#	18 1/8"	FLT2632/LT2632	26"/32"	18.9#	68.7#	40 3/4"
FLT1018/LT1018	10"/18"	3.0#	12.6#	18 1/8"	FLT2828/LT2828	28"/28"	21.4#	67.0#	43 3/8"
FLT1020/LT1020	10"/20"	3.0#	17.5#	18 1/8"	FLT2830/LT2830	28"/30"	21.4#	70.4#	43 3/8"
FLT1022/LT1022	10"/22"	3.0#	18.9#	18 1/8"	FLT832/LT2832	28"/32"	21.4#	73.9#	43 3/8"
FLT1024/LT1024	10"/24"	3.0#	20.4#	18 1/8"	FLT2834/LT2834	28"/34"	21.4#	77.3#	43 3/8"
FLT1212/LT1212	12"/12"	3.8#	10.6#	20 1/8"	FLT2026/LT2026	30"/30"	23.8#	75.6#	46 7/8"
FLT1214/LT1214	12"/14"	3.8#	11.9#	20 1/8"	FLT3230/LT3032	30"/32"	23.8#	79.2#	46 7/8"
FLT1216/LT1216	12"/16"	3.8#	13.1#	20 1/8"	FLT3034/LT3034	30"/34"	23.8#	82.9#	46 7/8"
FLT1218/LT1218	12"/18"	3.8#	14.4#	20 1/8"	FLT3036/LT3036	30"/36"	23.8#	86.5#	46 7/8"
FLT1220/LT1220	12"/20"	3.8#	19.9#	20 1/8"	FLT3232/LT3232	32"/32"	26.5#	84.7#	49 1/4"
FLT1222/LT1222	12"/22"	3.8#	21.5#	20 1/8"	FLT3234/LT3234	32"/34"	26.5#	88.6#	49 1/4"
FLT1224/LT1224	12"/24"	3.8#	23.1#	20 1/8"	FLT3236/LT3236	32"/36"	26.5#	92.4#	49 1/4"
FLT1414/LT1414	14"/14"	4.8#	13.5#	23 1/8"	FLT3434/LT3434	34"/34"	29.4#	94.4#	52 1/8"
FLT1416/LT1416	14"/16"	4.8#	14.9#	23 1/8"	FLT3436/LT3436	34"/36"	29.4#	98.4#	52 1/8"
FLT1420/LT1420	14"/18"	4.8#	16.3#	23 1/8"	FLT3636/LT3636	36"/36"	32.2#	104.5#	54 7/8"
FLT1420/LT1420	14"/20"	4.8#	22.5#	23 1/8"					

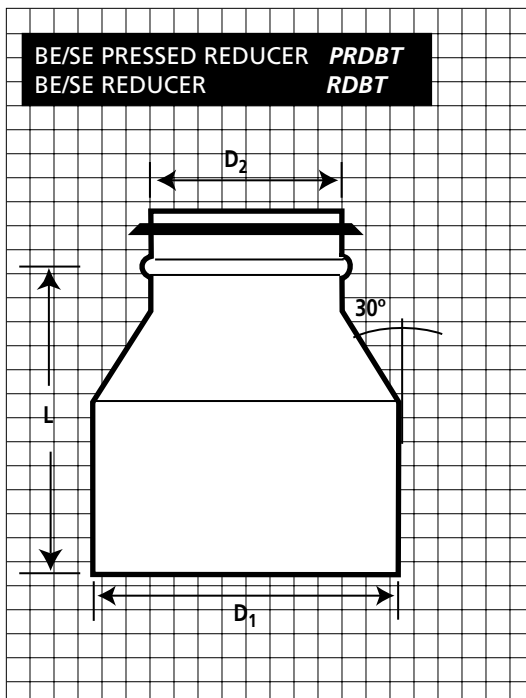
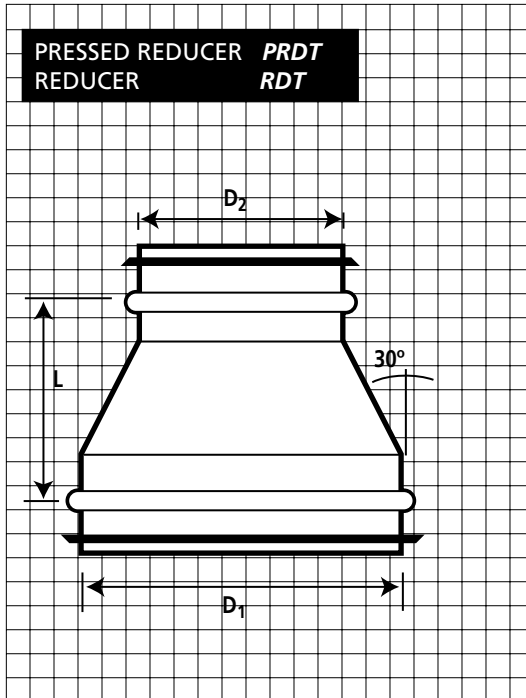

PRESSED REDUCERS					REDUCERS				
	D ₁ /D ₂	L	L	WT		D ₁ /D ₂	L	L	WT
		PRDT	PRBDT				RDT	RBDT	
PRDT43/PRDBT43	4"/3"	1 7/8"	3 3/8"	.4#	RDT148/RBDT148	14"/8"	8"	10"	4.9#
PRDT53/PRDBT53	5"/3"	2 3/4"	4 1/4"	.6#	RDT1410/RBDT1410	14"/10"	8"	10"	4.7#
PRDT43/PRDBT43	5"/4"	1 3/8"	3 3/8"	.6#	RDT1412/RBDT1412	14"/12"	10"	12"	4.9#
PRDT43/PRDBT43	6"/4"	3 3/8"	5 1/8"	.9#	RDT1610/RBDT1610	16"/10"	8"	10"	5.7#
PRDT43/PRDBT43	6"/5"	2 1/4"	4 1/4"	.8#	RDT1612/RBDT1612	16"/12"	8"	10"	5.4#
PRDT43/PRDBT43	7"/5"	3 3/8"	5 1/8"	1.2#	RDT1614/RBDT1614	16"/14"	10"	12"	5.7#
PRDT43/PRDBT43	7"/6"	2 3/4"	4 3/4"	1.1#	RDT1812/RBDT1812	18"/12"	8"	10"	6.5#
PRDT43/PRDBT43	8"/5"	4 1/2"	6 1/2"	1.5#	RDT1814/RBDT1814	18"/14"	8"	10"	6.1#
PRDT43/PRDBT43	8"/6"	3 3/8"	5 1/8"	1.4#	RDT1816/RBDT1816	18"/16"	10"	12"	6.4#
PRDT43/PRDBT43	8"/7"	2 3/4"	4 3/4"	1.3#	RDT2014/RBDT2014	20"/14"	8"	10"	9.4#
PRDT43/PRDBT43	9"/6"	4 1/2"	6 1/2"	1.7#	RDT2016/RBDT2016	20"/16"	8"	10"	8.7#
PRDT43/PRDBT43	9"/7"	3 3/8"	5 1/8"	1.8#	RDT2018/RBDT2018	20"/18"	10"	12"	9.2#
PRDT43/PRDBT43	9"/8"	2 3/4"	4 3/4"	1.5#	RDT2216/RBDT2216	22"/16"	8"	10"	10.4#
PRDT43/PRDBT43	10"/6"	5 3/8"	7 3/8"	2.0#	RDT2218/RBDT2218	22"/18"	8"	10"	9.7#
PRDT43/PRDBT43	10"/7"	4 1/2"	6 1/2"	1.9#	RDT2220/RBDT2220	22"/20"	10"	12"	10.1#
PRDT43/PRDBT43	10"/8"	3 3/8"	5 1/8"	1.8#	RDT2418/RBDT2418	24"/18"	8"	10"	11.5#
PRDT43/PRDBT43	10"/9"	2 3/4"	4 3/4"	1.7#	RDT2420/RBDT2420	24"/20"	8"	10"	10.7#
PRDT43/PRDBT43	12"/8"	5 3/8"	7 3/8"	2.5#	RDT2422/RBDT2422	24"/22"	10"	12"	11.0#
PRDT43/PRDBT43	12"/9"	4 1/2"	6 1/2"	2.4#	RDT2620/RBDT2620	26"/20"	8"	10"	15.2#
PRDT43/PRDBT43	12"/10"	3 3/8"	5 1/8"	2.2#	RDT2622/RBDT2622	26"/22"	8"	10"	14.1#
					RDT2624/RBDT2624	26"/24"	10"	12"	14.5#
					RDT2822/RBDT2822	28"/22"	8"	10"	16.5#
					RDT2824/RBDT2824	28"/24"	8"	10"	15.3#
					RDT2826/RBDT2826	28"/26"	10"	12"	15.7#
					RDT3024/RBDT3024	30"/24"	8"	10"	17.8#
					RDT3026/RBDT3026	30"/26"	8"	10"	16.4#
					RDT3028/RBDT3028	30"/28"	10"	12"	16.9#
					RDT3226/RBDT3226	32"/26"	8"	10"	19.1#
					RDT3228/RBDT3228	32"/28"	8"	10"	17.6#
					RDT3230/RBDT3230	32"/30"	10"	12"	18.0#
					RDT3428/RBDT3428	34"/28"	8"	10"	20.4#
					RDT3430/RBDT3430	34"/30"	8"	10"	18.7#
					RDT3432/RBDT3432	34"/32"	10"	12"	19.1#
					RDT3630/RBDT3630	36"/30"	8"	10"	21.6#
					RDT3632/RBDT3632	36"/32"	8"	10"	19.8#
					RDT3634/RBDT3634	36"/34"	10"	12"	20.3#

Eastern Sheet Metal Pressed Reducers are the world's first pressed HVAC reducers with a converging angle of 30 degrees and are protected by U.S. Patent 6,548,760.



EASTERN TIGHT™ TAKE OFFS & END CAPS

BELL MOUTH TAKE OFF PBT

	D ₁	R	WT.
PBT4	4"	.394"	0.4#
PBT5	5"	.472"	0.5#
PBT6	6"	.787"	0.6#
PBT7	7"	1.0"	0.7#
PBT8	8"	1.0"	0.8#
PBT9	9"	1.0"	0.9#
PBT10	10"	1.0"	1.1#
PBT12	12"	1.0"	1.3#

CONICAL TAKE OFF CTOT

	D ₁	WT.
CTOT14	14"	3.8#
CTOT16	16"	4.3#
CTOT18	18"	4.9#
CTOT20	20"	6.7#
CTOT22	22"	7.5#
CTOT24	24"	8.2#
CTOT26	26"	10.8#
CTOT28	28"	11.6#
CTOT30	30"	12.4#
CTOT32	32"	13.2#
CTOT34	34"	14.0#
CTOT46	36"	14.8#

STRAIGHT TAKE OFF TOT

	D ₁	WT.
TOT3	3"	0.6#
TOT4	4"	0.8#
TOT5	5"	1.0#
TOT6	6"	1.2#
TOT7	7"	1.3#
TOT8	8"	1.5#
TOT9	9"	1.7#
TOT10	10"	1.9#
TOT12	12"	2.3#
TOT14	14"	2.6#
TOT16	16"	3.0#
TOT18	18"	3.4#
TOT20	20"	4.8#
TOT22	22"	5.3#
TOT24	24"	5.7#
TOT26	26"	7.5#
TOT28	28"	0.1#
TOT30	30"	8.7#
TOT32	32"	9.3#
TOT34	34"	9.8#
TOT36	36"	10.4#

PRESSED END CAP PECT

	D ₁	WT.
PECT4	4"	0.4#
PECT5	5"	0.6#
PECT6	6"	0.7#
PECT7	7"	0.9#
PECT8	8"	1.0#
PECT9	9"	1.2#
PECT10	10"	1.4#
PECT12	12"	1.8#

END CAP ECT

	D ₁	WT.
ECT14	14"	2.6#
ECT16	16"	3.1#
ECT18	18"	3.7#
ECT20	20"	5.5#
ECT22	22"	6.4#
ECT24	24"	7.3#
ECT26	26"	11/8#
ECT28	28"	13.2#
ECT30	30"	14.6#
ECT32	32"	16.1#
ECT34	34"	17.7#
ECT36	36"	19.4#



EASTERN TIGHT™ MISCELLANEOUS

DAMPER

DT

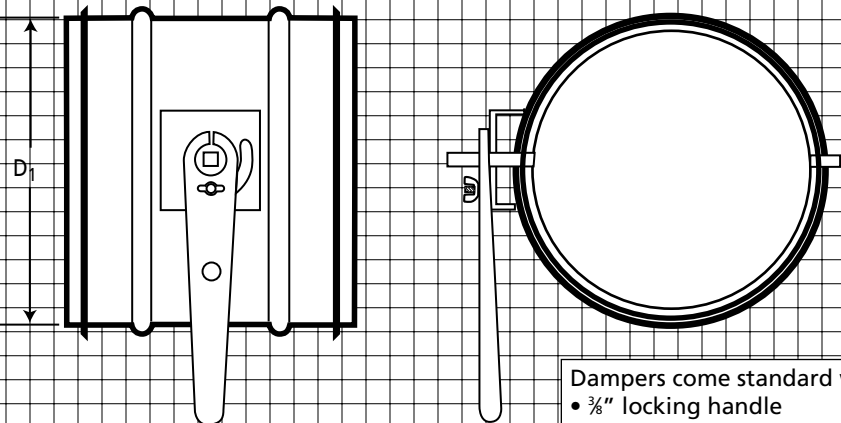

	D ₁	WT.
DT3	3"	1.5#
DT4	4"	1.7#
DT5	5"	1.9#
DT6	6"	2.1#
DT7	7"	2.3#
DT8	8"	2.5#
DT9	9"	2.7#
DT10	10"	2.9#
DT12	12"	3.4#
DT14	14"	3.8#
DT16	16"	4.2#
DT18	18"	4.7#
DT20	20"	6.3#
DT22	22"	7.0#
DT24	24"	7.6#
DT26	26"	9.8#
DT28	28"	10.6#
DT30	30"	11.5#
DT32	32"	12.3#
DT34	34"	13.2#
DT36	36"	14.1#

Dampers come standard with:

- 3/8" locking handle
- Nylon bushings
- Insulation stand off

Y-BRANCH

YT

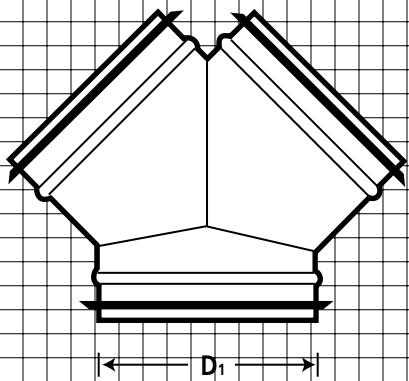

	D ₁	WT.
YT3	3"	1.6#
YT4	4"	2.4#
YT5	5"	3.3#
YT6	6"	4.4#
YT7	7"	5.5#
YT8	8"	6.8#
YT9	9"	8.3#
YT10	10"	9.8#
YT12	12"	13.3#
YT14	14"	17.4#
YT16	16"	22.0#
YT18	18"	27.1#
YT20	20"	41.7#
YT22	22"	49.5#
YT24	24"	58.0#
YT26	26"	81.7#
YT28	28"	93.7#
YT30	30"	106.4#
YT32	32"	120.0#
YT34	34"	134.4#
YT36	36"	149.6#

30° 2-PC. ELBOW

E30

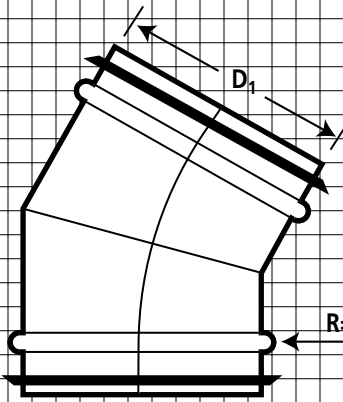

	D ₁	WT.
E303	3"	0.5#
E304	4"	0.7#
E305	5"	0.9#
E306	6"	1.3#
E307	7"	1.5#
E308	8"	1.9#
E309	9"	2.3#
E3010	10"	2.7#
E3012	12"	3.7#
E3014	14"	4.8#
E3016	16"	6.0#
E3018	18"	7.4#
E3020	20"	11.3#
E3022	22"	13.4#
E3024	24"	15.7#
E3026	26"	22.0#
E3028	28"	25.2#
E3030	30"	28.5#
E3032	32"	32.1#
E3034	34"	36.0#
E3036	36"	40.0#



EASTERN TIGHT™ INSTALLATION

SINGLE WALL SLIP FIT

Eastern Sheet Metal fittings are sized to slip into, and should be used with, Eastern Sheet Metal spiral duct. A tight fit is necessary to minimize friction loss and to promote proper sealing. Care should be taken during handling and installation to avoid dents and distortions that can cause improper fit or difficult installation.

1. Bring the bottom of the fitting collar into the spiral duct at a slight angle.
2. Carefully work the rest of the collar into the spiral duct until approximately one inch of the collar remains exposed between the end of the spiral duct and the stop bead of the fitting collar. Do not use a screwdriver or knife to help make the connection. Apply pressure with the heel of your hand or with your fist to help slip the fitting into the duct.
3. Push the fitting into the spiral duct until the stop bead meets the edge of the spiral duct.
4. Fasten the fitting into the spiral duct with screws per the chart to the right. The screws should be evenly spaced around the perimeter of the connection, approximately 1/2" back from the stop bead. Placement of the screws should be opposite of each other as demonstrate in the diagram.

Installation of
Single Wall Slip Fit

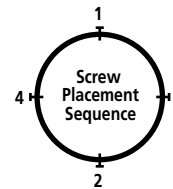
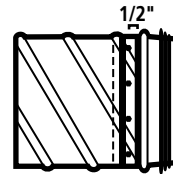
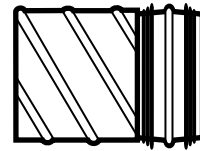
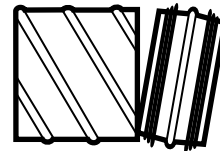

Installation of
Dual Wall Slip Fit

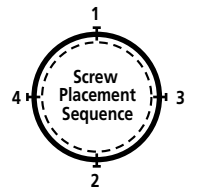
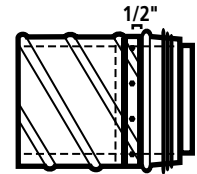
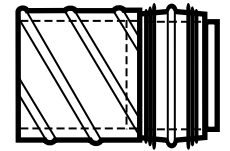
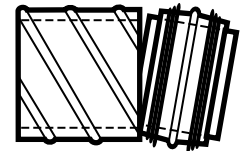

DUAL WALL SLIP FIT

The inner and outer collars of Eastern Sheet Metal fittings are sized to slip into, and should be used with, Eastern Sheet Metal spiral duct. The inner collar projects beyond the outer collar. This permits the inner collar to be started into the inner liner of the spiral duct in a manner similar to the single wall technique. A tight fit is necessary to minimize friction loss and to promote proper sealing. Care should be taken during handling and installation to avoid dents and distortions that can cause improper fit or difficult installation.

1. Bring the bottom of the inner fitting collar into the inner spiral duct at a slight angle.
2. Work the rest of the inner collar into the spiral duct.
3. When the inner collar is fully inserted, start the outer collar in the same manner.
4. Carefully work the rest of the collar into the spiral duct. Do not use a screwdriver or knife to help make the connection. Apply pressure with the heel of your hand or with your fist to help slip the fitting into the duct. Push the fitting into the spiral duct until the stop bead meets the edge of the spiral duct.
5. Fasten the fitting into the spiral duct with screws per the chart. The screws should be evenly spaced around the perimeter of the connection, approximately 1/2" back from the stop bead. Placement of the screws should be opposite of each other as demonstrated in the diagram.

DUCT DIAMETER	# OF SCREWS.
4" - 16"	3
18" - 22"	3
24" - 26"	3
28" - 30"	6
32" - 36"	7

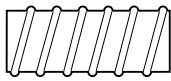
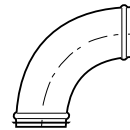
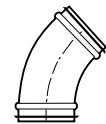
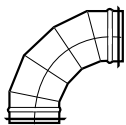
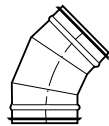
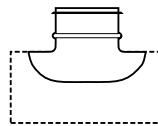
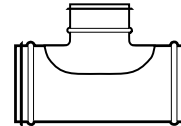
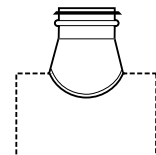
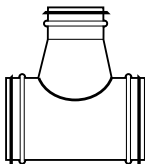
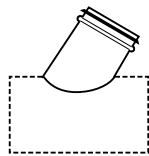
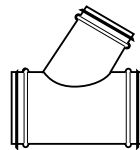
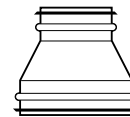
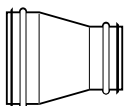
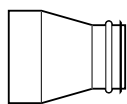
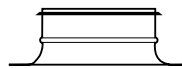
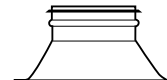
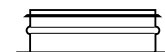
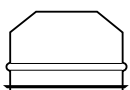
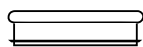
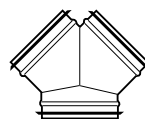
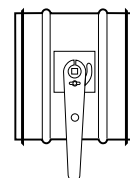
*SP**PCPT**FCPT**PE90T**PE45T**E90T**E45T**PFTT**PTT**FTCT**CTT**FLT**LT**PRDT**PRDBT**RDT**RDBT**PBT**CTOT**TOT**PECT**ECT**YT**DT**E30*

EASTERN TIGHT is a trademark of Eastern Sheet Metal, LLC and may not be used without prior written authorization.